

Features

HMMS Manual Motor Starter

Hyundai Manual Motor Starter, MMS series, realizes the function of molded case circuit breaker and thermal overload relay in one module. It enables perfect protection for overload, phase loss, short circuit and infrequent start control of 3-phase motors. MMS also can be used for the protection of distribution line as well as satisfied with the international standard IEC 60947-2 and IEC 60947-4-1.





Product Features

HYUNDAI ELECTRIC introduces the Rotary handle type of new MMS rating from 1 A to 32 A.

Function

- Phase-failure protection
- Short circuit protection
- Overload protection
- Frequent operation
- Disconnect switch

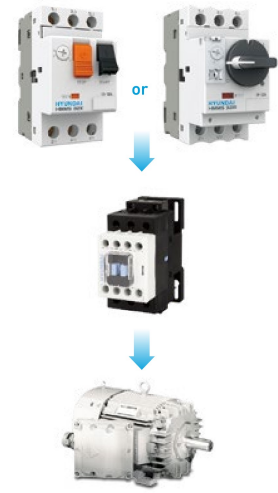
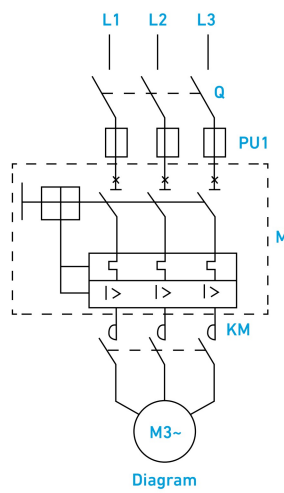

Features

- Standard: IEC 60947-2 / IEC 60947-4
- 50 % Less wiring: MCCB + Contactor + TOR -> MMS + Contactor
- Compact size: save 57 % space
- Green design: Recyclable plastic, no cadmium connection, RoHs
- Tool free installation: 35 mm Din-rail mounting



※ 44.5 mm width up to 32 AF, 61.2 mm width up to 80 AF.

Selection Table

HMMS Type

Model			HMMS32K									
												
Operation Type			Push-button									
No. of Poles			3									
Rated Current (In)			0.1~32 A									
Rated Operational Voltage (Ue)			Up to 690 V									
Rated Frequency (F)			50/60 Hz									
Rated Insulation Voltage (Ui)			690 V									
Rated Impulse Voltage (Uimp)			6 kV									
Utilization Category	IEC 60947-2 (Breaker)		Cat. A									
	IEC 60947-4 (Motor Starter)		AC 3									
Electrical/Mechanical Endurance (no. of Operations) Minimum			100,000/100,000									
Max Operating Frequency Per Hour (Ope./h)			25									
Temperature Compensation (Operation)			-20~+60 °C									
Instantaneous Short Circuit Release			13 × Ie max.									
Humidity			95% RH									
Altitude (m)			2,000									
Terminal Capacity (max)			10 mm ²									
Tightening Torque			2.5 N·m									
Function	Overload Protection		○									
	Phase Failure Protection		○									
	Test Button		○									
Weight (kg)			0.250									
Dimensions (H x D x W)			89.0 x 78.2 x 44.5									
Mounting			Clip in DIN Rail (35 mm x 7.5 mm)									
Installation Position			Vertical/Horizontal									
Options			AUX/AXT/SHT/UVT/Enclosure									
Rated Breaking Capacity (kA)	Rated Operational Current (Ie)	Setting Range (A)	AC220 V AC230 V AC240 V		AC400 V AC415 V		AC440 V AC460 V		AC500 V AC525 V		AC600 V AC690 V	
			Icu	Ics	Icu	Ics	Icu	Ics	Icu	Ics	Icu	Ics
	0.16	0.1-0.16	100	100	100	100	100	100	100	100	100	100
	0.25	0.16-0.25	100	100	100	100	100	100	100	100	100	100
	0.4	0.25-0.4	100	100	100	100	100	100	100	100	100	100
	0.63	0.4-0.63	100	100	100	100	100	100	100	100	100	100
	1	0.63-1	100	100	100	100	100	100	100	100	100	100
	1.6	1-1.6	100	100	100	100	100	100	100	100	100	100
	2.5	1.6-2.5	100	100	100	100	100	100	100	100	3	2.25
	4	2.5-4	100	100	100	100	100	100	100	100	3	2.25
	6.3	4-6.3	100	100	100	100	50	50	50	50	3	2.25
	10	6-10	100	100	100	100	15	15	10	10	3	2.25
	14	9-14	100	100	15	7.5	8	4	6	4.5	3	2.25
	18	13-18	100	100	15	7.5	8	4	6	4.5	3	2.25
	23	17-23	50	50	15	6	6	3	4	3	3	2.25
	25	20-25	50	50	15	6	6	3	4	3	3	2.25
	32	24-32	50	50	10	5	6	3	4	3	3	2.25
	40	25-40	-	-	-	-	-	-	-	-	-	-
	63	40-63	-	-	-	-	-	-	-	-	-	-
	80	56-80	-	-	-	-	-	-	-	-	-	-

HMMS32R

















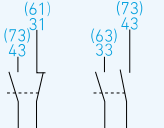
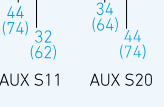

Rotary											
3											
0.1~32 A											
Up to 690 V											
50/60 Hz											
690 V											
6k V											
Cat. A											
AC 3											
100,000/100,000											
25											
-20~+60 °C											
13 × Ie max.											
95% RH											
2,000											
10 mm ²											
2.5 N·m											
o											
o											
o											
0.277											
89.8 x 89.5 x 44.5											
Clip in DIN Rail (35 mm x 7.5 mm)											
Vertical/Horizontal											
AUX/AXT/SHT/UVT/Handle											
AC220 V AC230 V AC240 V	AC400 V AC415 V	AC440 V AC460 V	AC500 V AC525 V	AC600 V AC690 V							
Icu	Ics	Icu	Ics	Icu	Ics	Icu	Ics	Icu	Ics		
100	100	100	100	100	100	100	100	100	100		
100	100	100	100	100	100	100	100	100	100		
100	100	100	100	100	100	100	100	100	100		
100	100	100	100	100	100	100	100	100	100		
100	100	100	100	100	100	100	100	100	100		
100	100	100	100	100	100	100	100	100	100		
100	100	100	100	100	100	100	100	3	2.25		
100	100	100	100	100	100	100	100	3	2.25		
100	100	100	100	50	50	50	50	3	2.25		
100	100	100	100	15	15	10	10	3	2.25		
100	100	15	7.5	8	4	6	4.5	3	2.25		
100	100	15	7.5	8	4	6	4.5	3	2.25		
50	50	15	6	6	3	4	3	3	2.25		
50	50	15	6	6	3	4	3	3	2.25		
50	50	10	5	6	3	4	3	3	2.25		
-	-	-	-	-	-	-	-	-	-		
-	-	-	-	-	-	-	-	-	-		
-	-	-	-	-	-	-	-	-	-		

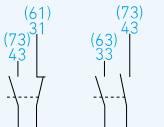
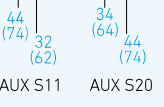
HMMS80K

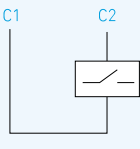

Push-button											
3											
25~80 A											
Up to 690 V											
50/60 Hz											
690 V											
6 kV											
Cat. A											
AC 3											
30,000/50,000											
25											
-20~+60 °C											
13 × Ie max.											
95% RH											
2,000											
25 mm ²											
4.5 N·m											
o											
o											
o											
0.682											
120.0 x 113.0 x 61.2											
Clip in DIN Rail (35 mm x 7.5 mm)											
Vertical/Horizontal											
AUX											
AC220 V AC230 V AC240 V	AC400 V AC415 V	AC440 V AC460 V	AC500 V AC525 V	AC600 V AC690 V							
Icu	Ics	Icu	Ics	Icu	Ics	Icu	Ics	Icu	Ics		
-	-	-	-	-	-	-	-	-	-		
-	-	-	-	-	-	-	-	-	-		
-	-	-	-	-	-	-	-	-	-		
-	-	-	-	-	-	-	-	-	-		
-	-	-	-	-	-	-	-	-	-		
-	-	-	-	-	-	-	-	-	-		
-	-	-	-	-	-	-	-	-	-		
-	-	-	-	-	-	-	-	-	-		
-	-	-	-	-	-	-	-	-	-		
-	-	-	-	-	-	-	-	-	-		
-	-	-	-	-	-	-	-	-	-		
-	-	-	-	-	-	-	-	-	-		
-	-	-	-	-	-	-	-	-	-		
100	100	50	25	50	25	10	5	5	3		
100	100	50	25	50	25	10	5	5	3		
100	100	15	7.5	10	6	4	4	2	2		

Accessories

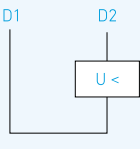
Accessories	Ordering Information	Electrical Diagram	Contact	Category				Weight (g)
				Ui (AC/V)	Ue (V)	Ie (A)	VA	
Auxiliary Switch Front Mounting 	MMS32K AUX T11	21  22 13  14	1NO 1NC	250	240	2.5	120	16
	MMS32K AUX T20	23  24 13  14	2NO					
Auxiliary Switch Side Mounting 	MMS32K AUX S11		1NO 1NC	690	690	6	720	40
	MMS32K AUX S20	 AUX S11 AUX S20	2NO					
Auxiliary Switch Side Mounting 	MMS80K AUX S11		1NO 1NC	690	690	6	720	40
	MMS80K AUX S20	 AUX S11 AUX S20	2NO					
Failure Alarm Side Mounting 	MMS32K AXT 0110		Failure contact: NC Auxiliary contact: NO	690	240	2.5 (95-96 & 97-98) Failure contact	72	40
	MMS32K AXT 0101		Failure contact: NC Auxiliary contact: NC					
	MMS32K AXT 1010		Failure contact: NO Auxiliary contact: NO	690	690	6 (51-52 & 53-54) Auxiliary contact	720	
	MMS32K AXT 1001		Failure contact: NO Auxiliary contact: NC					
Shunt Trip Relay 	MMS32K SHT 110		Uc = 110 V, 50/60 Hz				90	
	MMS32K SHT 240		Uc = 220/240 V, 50/60 Hz					
	MMS32K SHT 380		Uc = 380 V, 50/60 Hz					
Under Voltage Trip Relay 	MMS32K UVT 110		Uc = 110 V, 50/60 Hz				90	
	MMS32K UVT 240		Uc = 220/240 V, 50/60 Hz					
	MMS32K UVT 380		Uc = 380 V, 50/60 Hz					

Enclosure

• MMS32K ENC

Case cover of MMS enclosure is specifically designed with dust-proof and corrosive-proof structure.

Therefore, it is the optimum product to use in dusty areas such as cement plants, cotton mills as well as in the presence of corrosive gas or liquid (ex: explosive, flammable gas) such as fertilizer, refinery, and plating plant.

- Operating temp.: -20 ~ +60 °C
- Degree of protection: IP55
- Conforming to standards: IEC 60947-2, IRC 60947-4-1
- Operational voltage Ue: 690 V
- Material: Polycarbonate

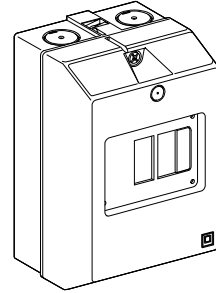

Extension Handle (TFH)

• TFH MMS32R

MMS extension handle is a rotary type handle accessory which can be attached to the front to control and verify the On, Trip, Off condition of manual.

Motor starters under the situation of closing panel.

- Application model: MMS32R
- Operating temp.: -20~+60 °C
- Degree of protection: IP65
- Locking device: Lockable in on/off position
- Material: PA66

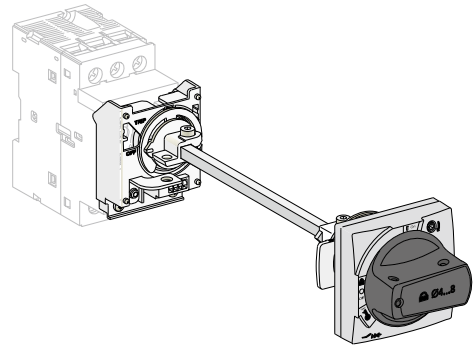

Mounting



Technical Data

Mounting

35 mm Din-Rail for mounting

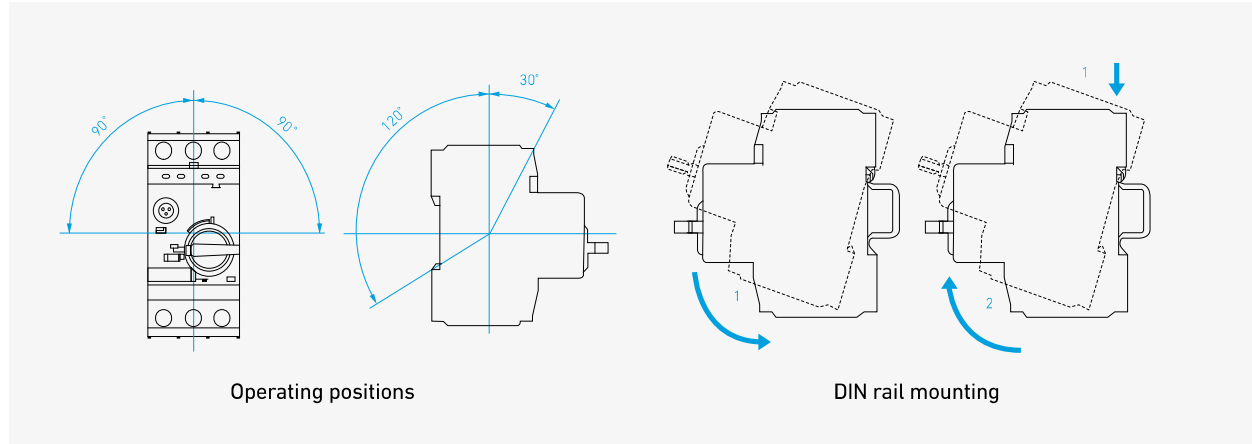

Caution for thermal adjustments

1. Keep the setting range as shown below.
2. Moving counterclockwise out of the setting range may cause the damage of the device.
3. Calibration by ambient air temperature

A: Set to one point lower	Calibrated automatically	B: Set to one point higher
-20 °C	-5 °C	+40 °C
		+60 °C

In case of using out of the standard air temperature range (-5°C~ + 40°C) it needs to be calibrated by one point

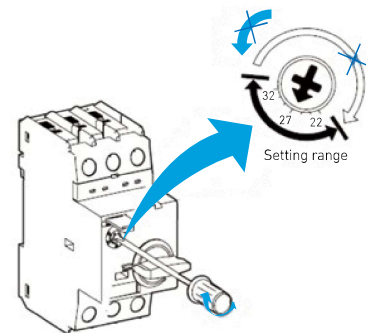

Dial setting method

Environment

Ambient air temperature

storage: -50... + 80 °C

operation: -20... + 60 °C

Ambient temperature compensation: -20... + 60 °C

Maximum operating altitude: 2,000 m

Protection degree: IP20

Shock resistance: 25 g

Vibration resistance: 5~150 Hz

Product side by side

When several products MMS32K/MMS32R/MMS80K are mounted side by side, the thermal trip setting I_r maybe need to be adjusted up to 1.1 X_{In} .

Don't exceed the maximum thermal setting I_r .

(ex: MMS32K 0010, thermal setting range: 6...10, don't adjust I_r above 10 A)

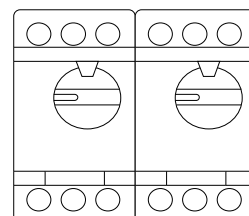

Terminals

Model	Terminal Screw	Applicable Wire Size (mm ²)	Ring Tongue Terminal (mm ²)	Screwing Torque (kgf.cm)
0.1-0.16 A	M4	1~10 mm ² (Hard cooper cable) 1~6 mm ² (Softcable)	Boreφ3.5, Maximum outsideφ 8.0	1.2 N.M
0.16-0.25 A	M4	1~10 mm ² (Hard cooper cable) 1~6 mm ² (Softcable)	Boreφ3.5, Maximum outsideφ 8.0	1.2 N.M
0.25-0.4 A	M4	1~10 mm ² (Hard cooper cable) 1~6 mm ² (Softcable)	Boreφ3.5, Maximum outsideφ 8.0	1.2 N.M
0.4-0.63 A	M4	1~10 mm ² (Hard cooper cable) 1~6 mm ² (Softcable)	Boreφ3.5, Maximum outsideφ 8.0	1.2 N.M
0.63-1 A	M4	1~10 mm ² (Hard cooper cable) 1~6 mm ² (Softcable)	Boreφ3.5, Maximum outsideφ 8.0	1.2 N.M
1-1.6 A	M4	1~10 mm ² (Hard cooper cable) 1~6 mm ² (Softcable)	Boreφ3.5, Maximum outsideφ 8.0	1.2 N.M
1.6-2.5 A	M4	1~10mm ² (Hard cooper cable) 1~6mm ² (Softcable)	Boreφ3.5, Maximum outsideφ 8.0	1.2 N.M
2.5-4 A	M4	1~10 mm ² (Hard cooper cable) 1~6 mm ² (Softcable)	Boreφ3.5, Maximum outsideφ 8.0	1.2 N.M
4-6.3 A	M4	1~10mm ² (Hard cooper cable) 1~6mm ² (Softcable)	Boreφ3.5, Maximum outsideφ 8.0	1.2 N.M
6-10 A	M4	1~10 mm ² (Hard Cooper Cable) 1~6 mm ² (Softcable)	Boreφ3.5, Maximum outsideφ 8.0	1.2 N.M
9-14 A	M4	1~10 mm ² (Hard cooper cable) 1~6 mm ² (Softcable)	Boreφ3.5, Maximum outsideφ 8.0	1.2 N.M
13-18 A	M4	1~10 mm ² (Hard cooper cable) 1~6 mm ² (Softcable)	Boreφ3.5, Maximum outsideφ 8.0	1.2 N.M
17-23 A	M4	1~10 mm ² (Hard cooper cable) 1~6 mm ² (Softcable)	Boreφ3.5, Maximum outsideφ 8.0	1.2 N.M
20-25 A	M4	1~10 mm ² (Hard cooper cable) 1~6 mm ² (Softcable)	Boreφ3.5, Maximum outsideφ 8.0	1.2 N.M
24-32 A	M4	1~10 mm ² (Hard cooper cable) 1~6 mm ² (Softcable)	Boreφ3.5, Maximum outsideφ 8.0	1.2 N.M
25-40 A	M8	2.5~25 mm ² (Hard cooper cable) 2.5~16 mm ² (Softcable)	-	3.5 N.M
40-63 A	M8	2.5~25 mm ² (Hard cooper cable) 2.5~16 mm ² (Softcable)	-	3.5 N.M
56-80 A	M8	2.5~25 mm ² (Hard cooper cable) 2.5~16 mm ² (Softcable)	-	3.5 N.M

Technical Data

Application for-3Phase Motors, AC-3

Rated Current (A)	Setting Range (A)	3-Phase [kW] (50/60 Hz)					
		AC230/240 V	400 V	415 V	440 V	500 V	690 V
0.16	0.1-0.16	-	-	-	-	-	-
0.25	0.16-0.25	-	0.06	0.06	-	-	-
0.4	0.25-0.4	-	0.09	0.09	-	-	-
0.63	0.4-0.63	-	0.12	0.12	0.2	0.25	0.37
1	0.63-1	-	0.25	0.25	0.5	0.5	0.55
1.6	1-1.6	-	0.37	0.37	0.55	0.75	1.1
2.5	1.6-2.5	0.5	0.75	0.75	1.1	1.1	1.5
4	2.5-4	0.5	1.5	1.5	2	2.2	3
6.3	4-6.3	1.1	2.2	2.2	3	3.7	4
10	6-10	2.2	4	4	5	5.5	7.5
14	9-14	3	5.5	5.5	7.5	7.5	9
18	13-18	5	7.5	7.5	9	9	15
23	17-23	6.5	11	11	11	11	18.5
25	20-25	6.5	11	11	15	15	18.5
32	24-32	10	15	15	18.5	20	22
40	25-40	10	20	20	25	30	30
63	40-63	20	30	35	40	50	60
80	56-80	25	35	40	50	55	60

HMMS32K/R

Thermal Magnetic Tripping Curve

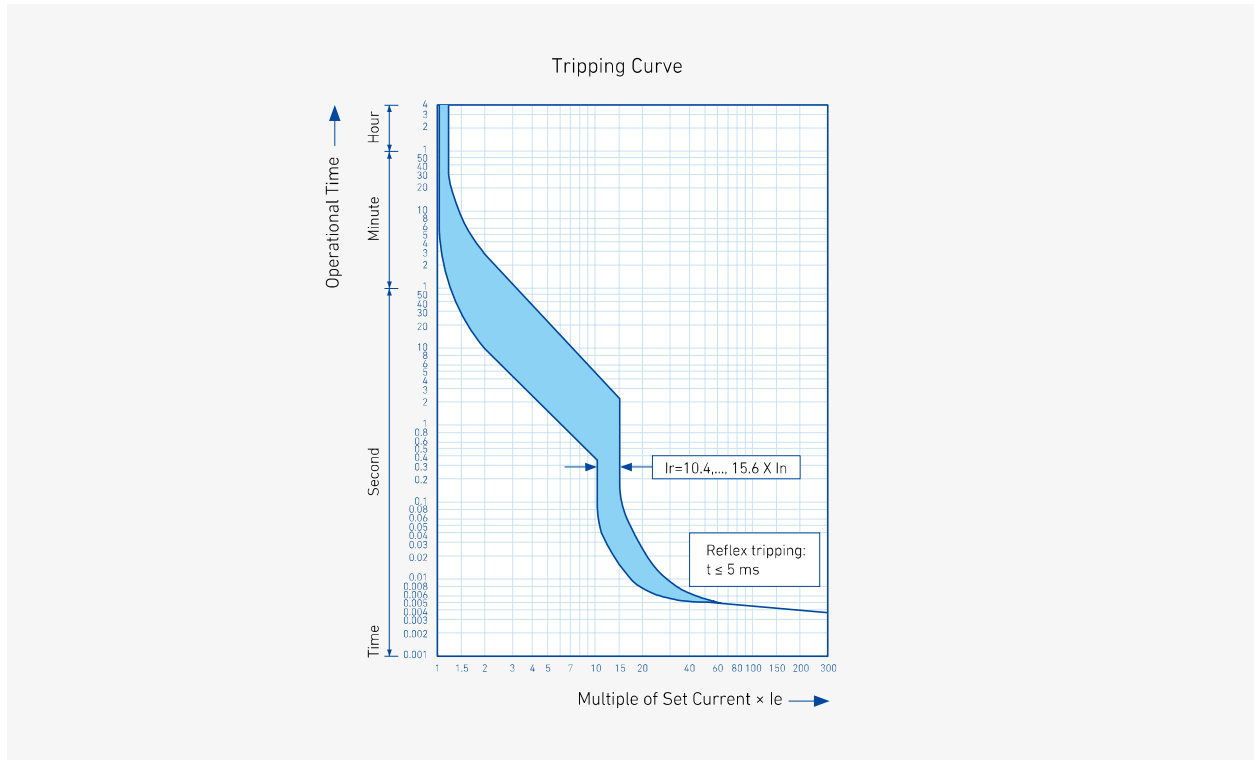

Current Limitation on Short Circuit HMMS32K/R

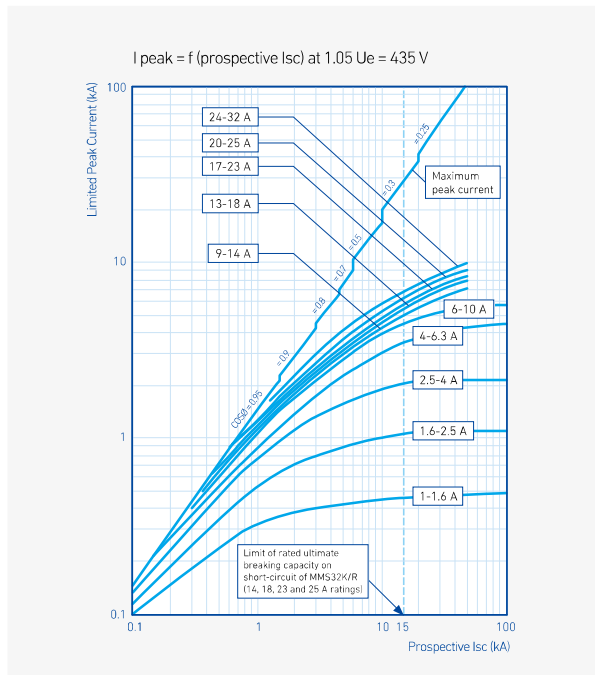

Thermal Limit on Short Circuit HMMS32K/R

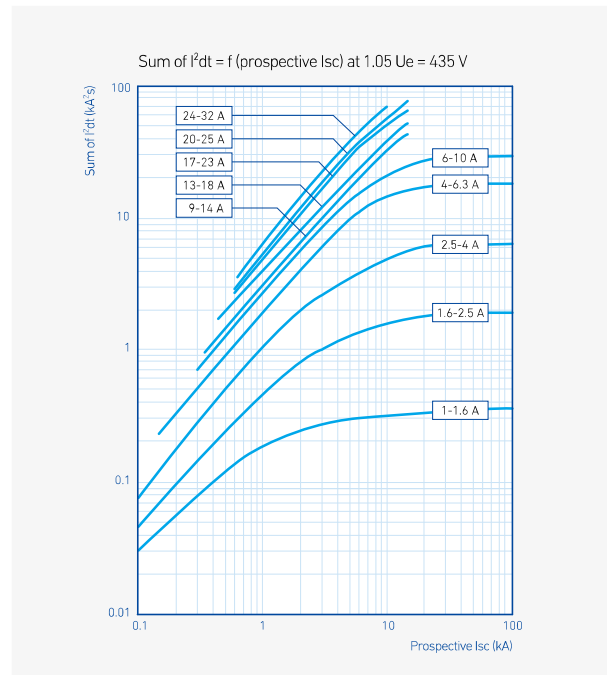

Technical Data

HMMS80K

Thermal Magnetic Tripping Curve

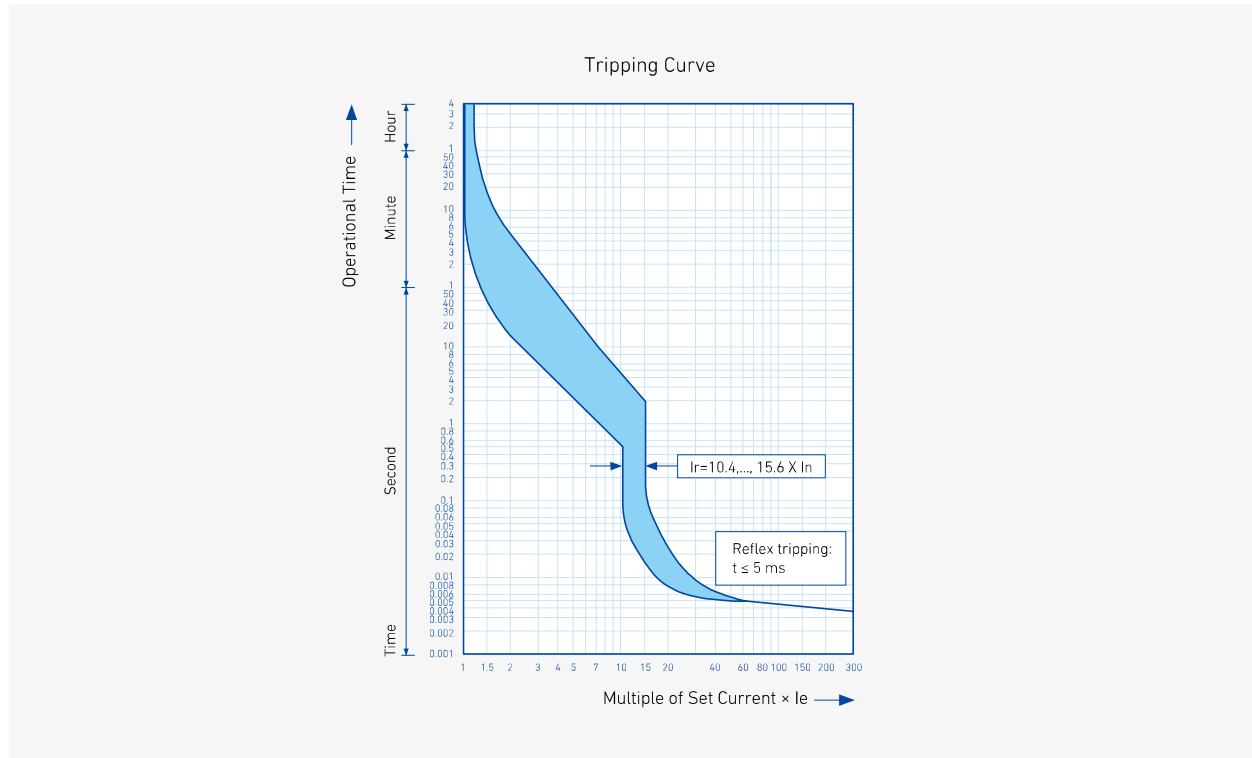

Current Limitation on Short Circuit

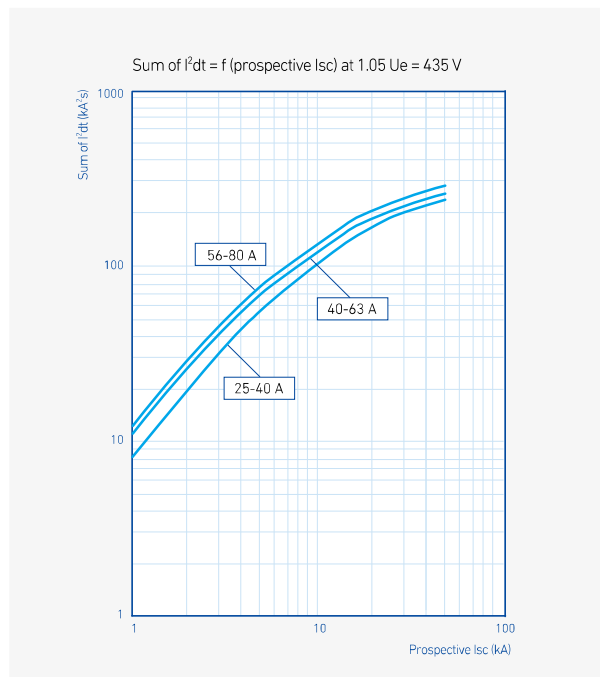

Thermal Limit in kA² in the Magnetic Operating Zone

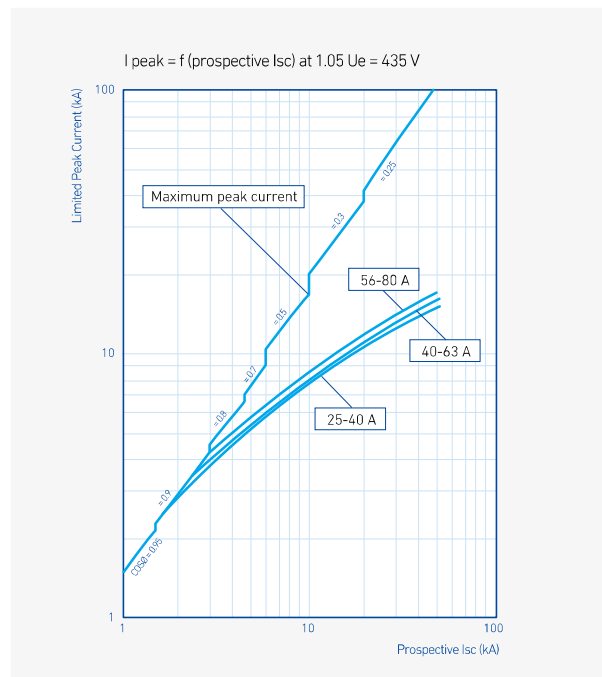

Dimensions

HMMS

HMMS32K

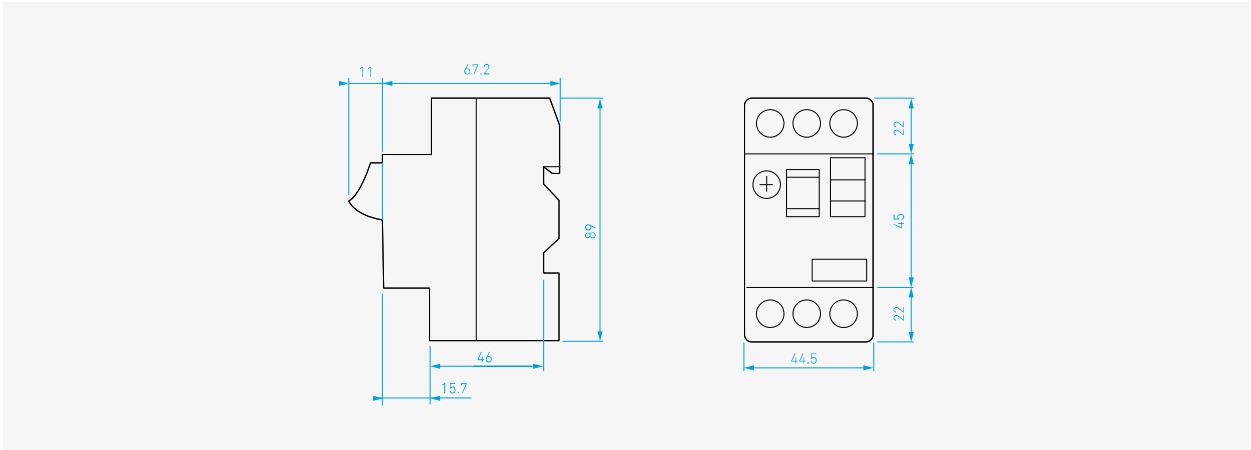

HMMS32R

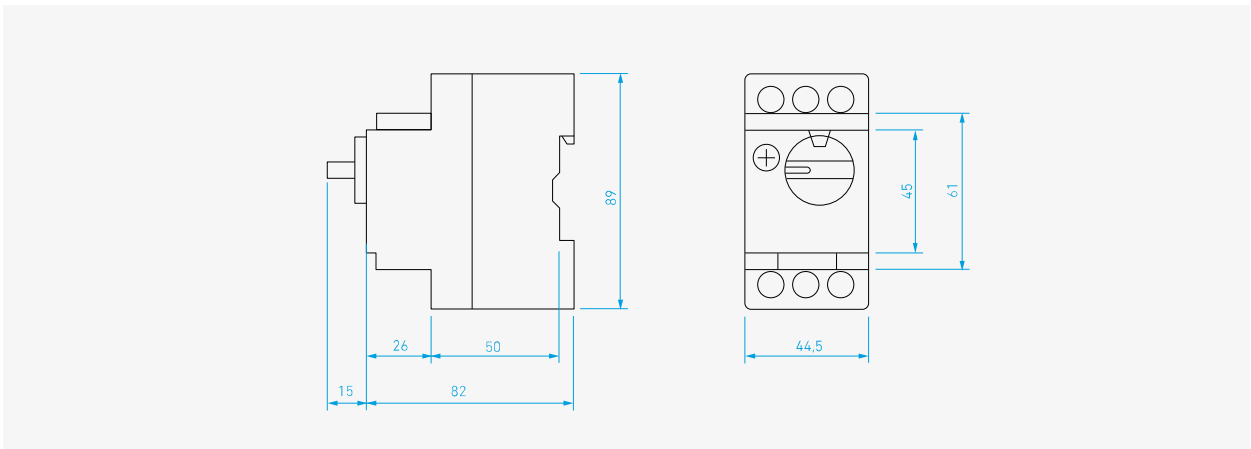

HMMS80K

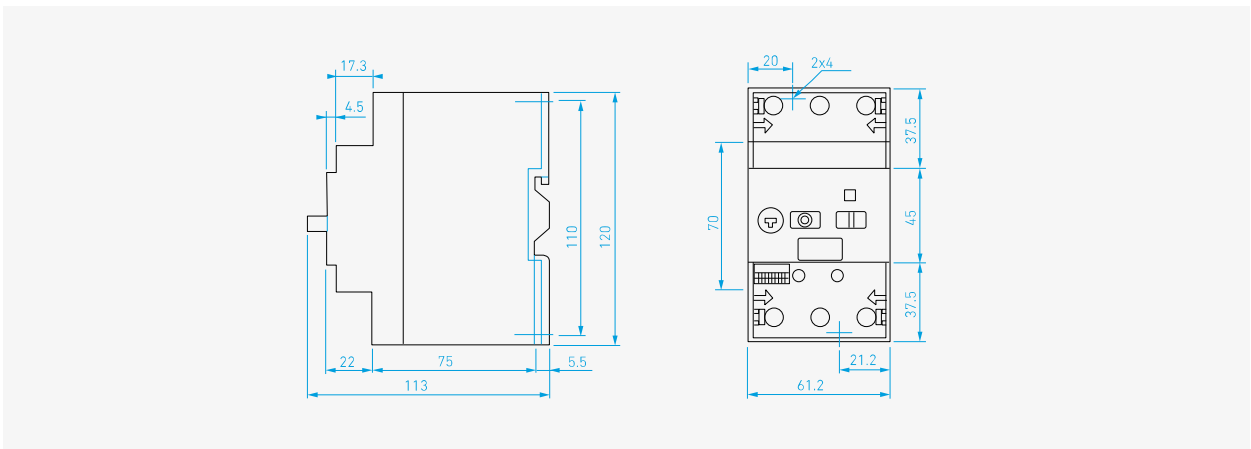

Dimensions

Accessories

Top Mounting: Auxiliary Switch

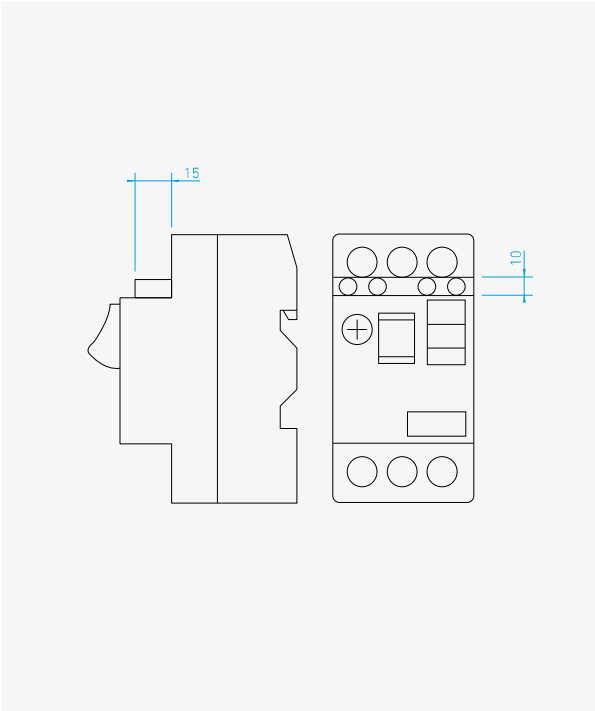

Side Mounting: Auxiliary Switch

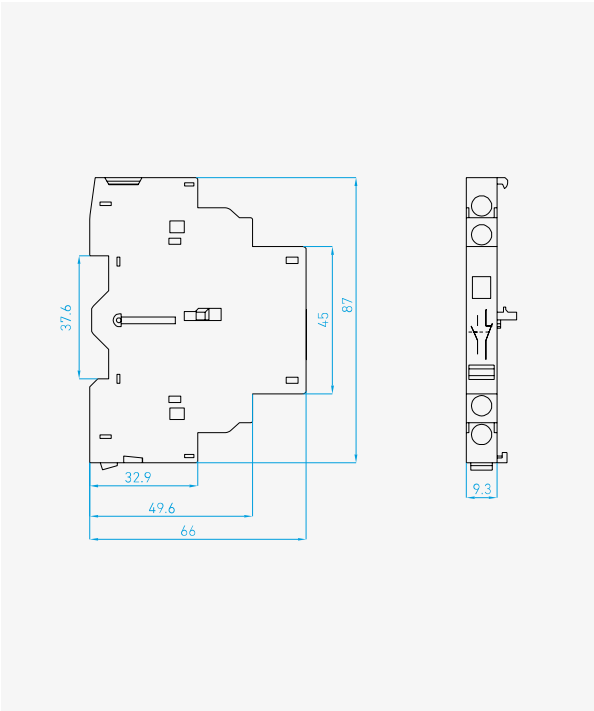

Side Mounting: Alarm Switch

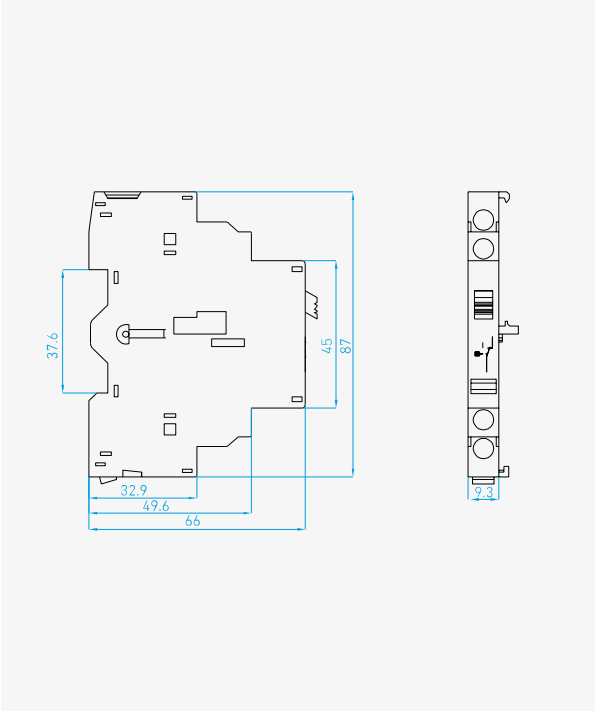

Side Mounting: Shunt Trip/UVT

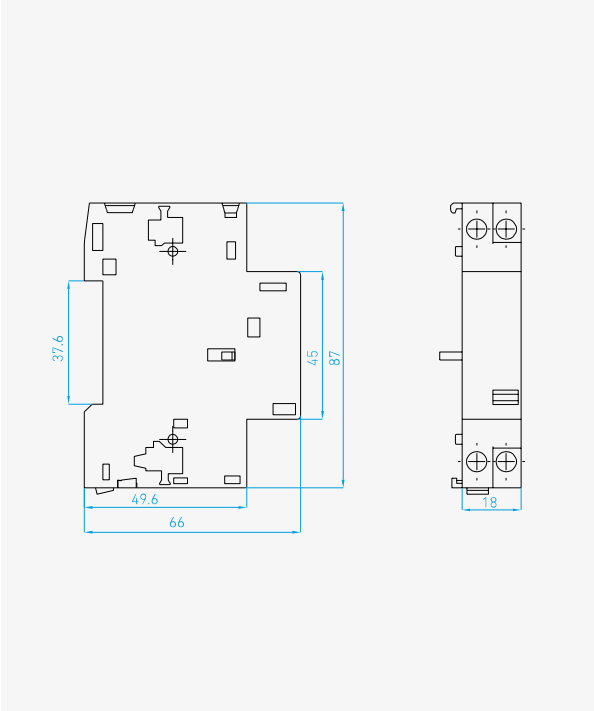

HMMS Ordering Information

Ordering Guidelines

Code	Rated Current Setting Range (A)	Unit (EA)	Handle Type
MMS32K 0P16	0.1-0.16	50	Push button
MMS32K 0P25	0.16-0.25		
MMS32K 0P40	0.25-0.4		
MMS32K 0P63	0.4-0.63		
MMS32K 1P00	0.63-1		
MMS32K 01P6	1-1.6		
MMS32K 02P5	1.6-2.5		
MMS32K 0004	2.5-4		
MMS32K 06P3	4-6.3		
MMS32K 0010	6-10		
MMS32K 0014	9-14		
MMS32K 0018	13-18		
MMS32K 0023	17-23		
MMS32K 0025	20-25		
MMS32K 0032	24-32		
MMS32R 0P16	0.1-0.16		
MMS32R 0P25	0.16-0.25		
MMS32R 0P40	0.25-0.4		
MMS32R 0P63	0.4-0.63		
MMS32R 1P00	0.63-1		
MMS32R 01P6	1-1.6		
MMS32R 02P5	1.6-2.5		
MMS32R 0004	2.5-4		
MMS32R 06P3	4-6.3		
MMS32R 0010	6-10		
MMS32R 0014	9-14		
MMS32R 0018	13-18		
MMS32R 0023	17-23		
MMS32R 0025	20-25		
MMS32R 0032	24-32		
MMS80K 0040	25-40	14	Push button
MMS80K 0063	40-63		
MMS80K 0080	56-80		